

LIFTING LUG FOR SHELL COVER,
CHANNEL AND CHANNEL COVER

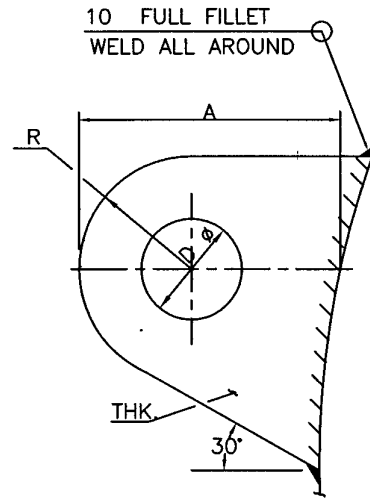

LIFTING LUG FOR
FLOATING HEAD COVER

SHELL I. D.	A	D	R	THK.
UPTO 450	65	25	28	12
451 - 1000	75	30	35	16
1001 - 1200	100	30	35	20
1201 & ABOVE	CUSTOM DESIGN			

NOTES: -

1. ALL DIMENSIONS ARE IN mm UNLESS STATED OTHERWISE.
2. MATERIAL SHALL BE COMPATIBLE WITH PART IT IS WELDED TO. (USE BOILER QUALITY FOR CARBON STEEL)
3. USE TWO LIFTING LUGS EACH FOR CHANNEL AND SHELL COVER AND ONE FOR CHANNEL COVER AND FLOATING HEAD COVER.

3	27.01.09	REAFFIRMED AND REISSUED AS STANDARD	VPR <i>[Signature]</i>	RKG <i>[Signature]</i>	AKM <i>[Signature]</i>	VC
2	26.03.04	REAFFIRMED AND REISSUED AS STANDARD	MKD	JV/PK	SSA	SKG
Rev. No.	Date	Purpose	Prepared by	Checked by	Stds. Committee Convener	Stds. Bureau Chairman
						Approved by