

5	31.10.19	REAFFIRMED AND REISSUED AS STANDARD	DP	NSK	KJH	RKT
4	06.05.14	REVISED AND REISSUED AS STANDARD	GCP	KA	RKT	SC
3	27.01.09	REAFFIRMED AND REISSUED AS STANDARD	VPR	RKG	AKM	VC
Rev No	Date	Purpose	Prepared by	Checked by	Stds Committee Convener	Stds Bureau Chairman
						Approved by

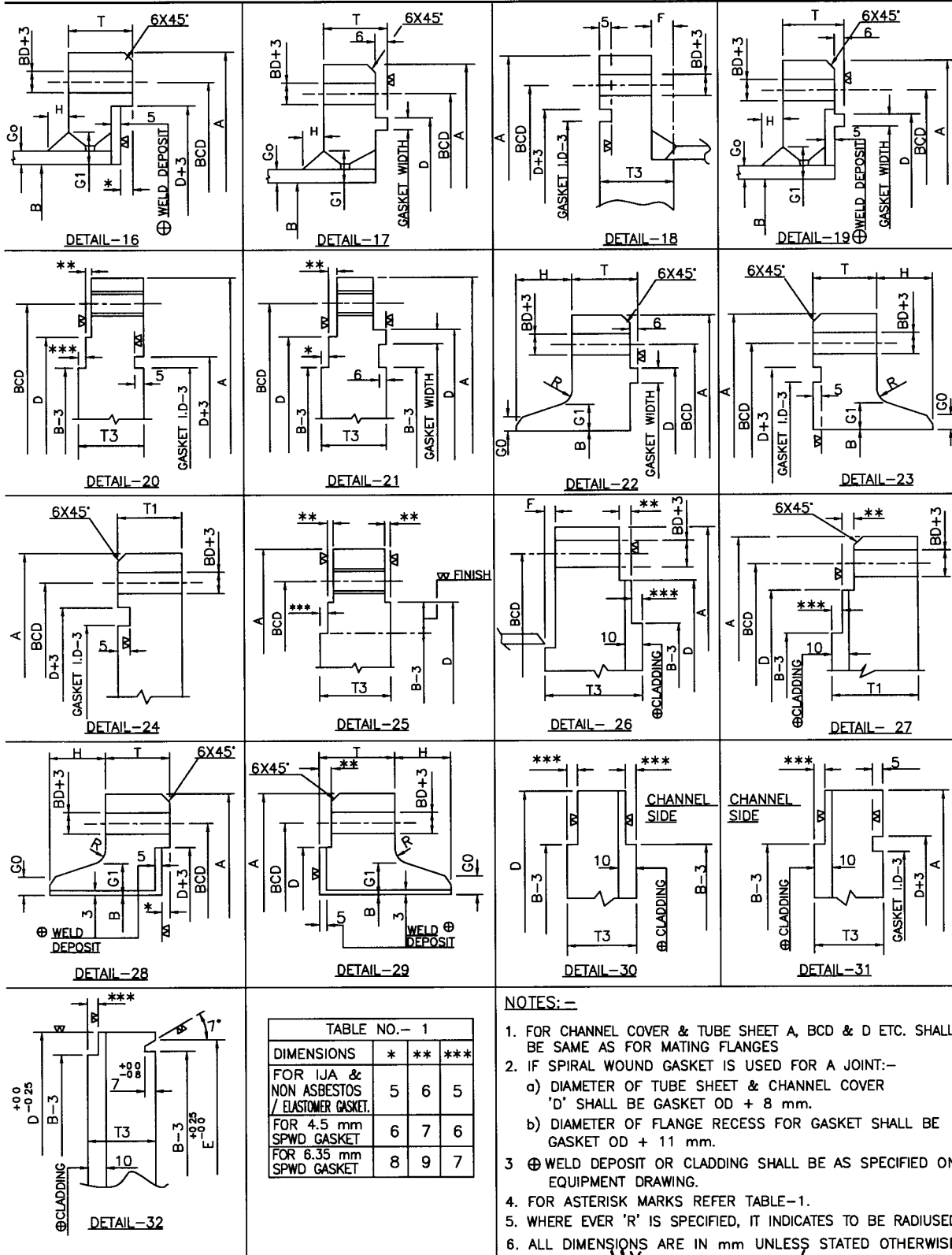

5	31.10.19	REAFFIRMED AND REISSUED AS STANDARD	DP	NSK	KJH	RKT
4	06.05.14	REVISED AND REISSUED AS STANDARD	GCP	KA	RKT	SC
3	27.01.09	REAFFIRMED AND REISSUED AS STANDARD	VPR	RKG	AKM	VC
Rev No	Date	Purpose	Prepared by	Checked by	Stds Committee Convener	Stds Bureau Chairman
Approved by						